

4

3

DWG NO.	SHT	REV
	1	A

1

REVISIONS				
ZONE	REV.	DESCRIPTION	DATE	APPROVED
-	A	INITIAL RELEASE	02/12/2011	M.S.

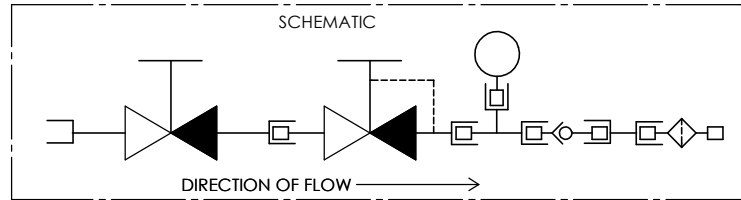
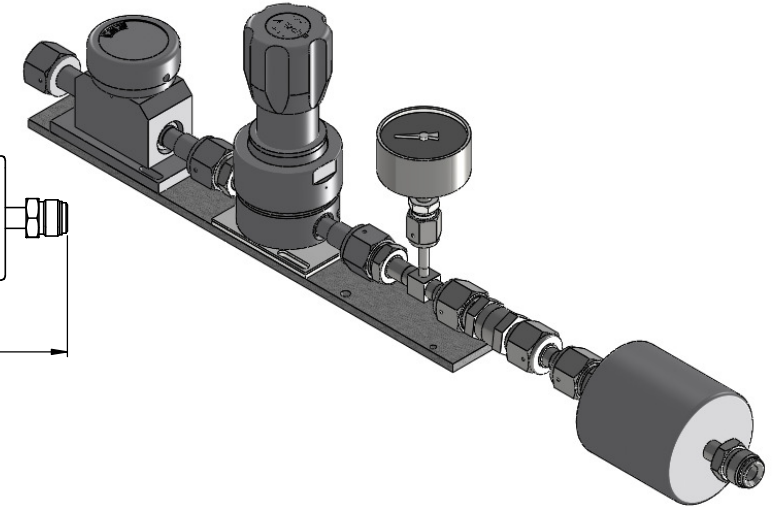
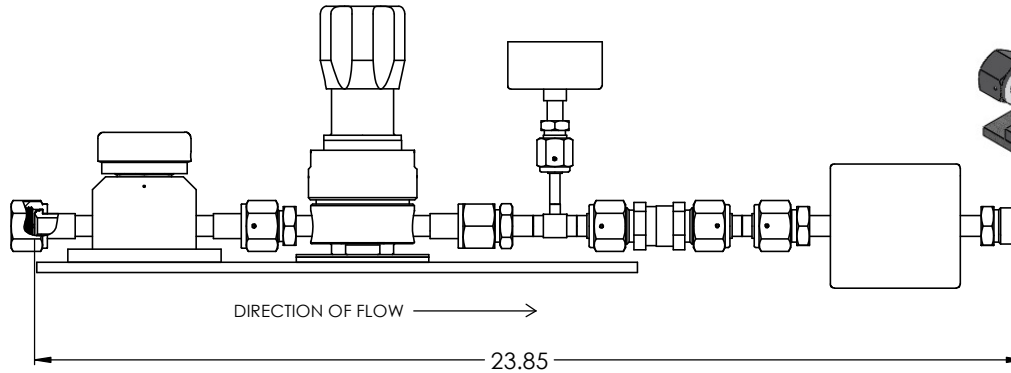
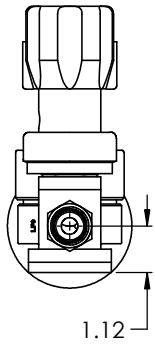

NEXT ASSY	APPROVALS	DATE	INTERPRET DIMENSIONS AND TOLERANCES PER ASME Y14.5M 1994 STANDARDS.	 SilPac® SANTA CLARA, CALIFORNIA
	DRAWN M.SEROTTA	03/05/2011	UNLESS OTHERWISE SPECIFIED ALL DIMENSIONS ARE IN INCHES.	
	CHECKED	---	TOLERANCES	SURFACES .XX ± 0.01 .XXX ± 0.005 ANGLES ± 5° 63 ✓
	ENGINEER	---	THIRD ANGLE PROJECTION	
	APPROVED	---	MATERIAL	SIZE B DWG NO. SP-GSA-132A-MKT REV A SCALE 2:1 DO NOT SCALE DRAWING Sheet 1 of 1
			FINISH	
THIS DOCUMENT CONTAINS CONFIDENTIAL INFORMATION OF SilPac. THIS DOCUMENT AND THE INFORMATION CONTAINED IN IT CANNOT BE COPIED OR DISCLOSED IN WHOLE OR IN PART WITHOUT THE EXPRESS WRITTEN CONSENT OF SilPac, AND MUST BE RETURNED TO SilPac UPON REQUEST.			SEE BOM	

4

3

2