



# SERIES AZ 30, 35 & 36

## 1/4 INCH DIAPHRAGM VALVE

Springless – manual and pneumatic (NC & NO)

- Replaceable seat
- 316L SS construction
- Operating pressures from 125 psig (9 bar) to 3,000 psig (207 bar)
- 10  $\mu$ m. (0.25  $\mu$ m) Ra avg. standard surface finish
- LOTO options
- Flow capacity 0.23 to 0.29  $C_v$
- Constant bleed option 5, 8 and 15 slpm of N<sub>2</sub> @ 80 psig (5.5 bar) refer to PN 430
- Forged body construction for integral fittings and tube stub (P porting)
- Bar stock body for welded fitting and multi-port options (PW porting)
- Multi-port options available (refer to page 4)
- Two step pneumatic valve option: dual operation – metered or full open
- Installation and operating instructions available at [www.aptech-online.com](http://www.aptech-online.com) in the Tech Briefs section

### Manual valves

	PSIG / BAR	
	250 / 17	3,000 / 207
<b>AZ 3600</b> – Round knob, multi-turn		●
<b>AZ 3625</b> – Lever valve, 1/4 turn – LOTO, PL 225 optional – Lever position indicates valve status		●
<b>AZ 3650</b> – Round knob, 1/4 turn – Open/closed status indication window – Switch option for remote monitoring		●
<b>AZ 3652</b> – Round knob, 1/4 turn – Open/closed status indication window – Unique design combines scalloped round knob with raised rectangular section	●	
<b>AZ 3657 and 3659</b> – Round knob, 1/4 turn – Pull, then turn to open – operational safety feature – Open/closed status indication window – LOTO – integral standard feature	●	●
	AZ 3659	AZ 3657

### Pneumatic valves, normally closed (NC)

	PSIG / BAR			
	125 / 9	145 / 10	300 / 21	3,000 / 207
<b>AZ 3000 and 3002</b> – Switch option for remote monitoring				●
<b>AZ 3540</b>		●		
<b>AZ 3540VS</b>	●			
<b>AZ 3542</b>	●			
<b>AZ 3550</b> – Switch option for remote monitoring			●	
<b>AZ 3571</b> – Dual mode – metered or full open	●			

### Pneumatic valve, normally open (NO)

	PSIG / BAR	
	250 / 17	3,000 / 207
<b>AZ 3080</b> – Switch option for remote monitoring		●
<b>AZ 3580</b> – Switch option for remote monitoring	●	

All specifications subject to change without notice.

ENGINEERING DATA — SERIES AZ 30, 35 & 36 1/4 INCH VALVE ARRAY

# HIGH PURITY ~ HIGH VALUE

## Engineering Data — Manual valves

Operating pressure	AZ 3652, 3659 AZ 3600, 3625, 3650, 3657	Vacuum to 250 psig (17 bar) Vacuum to 3,000 psig (207 bar)
Flow coefficient (C <sub>v</sub> )	AZ 3600, 3625, 3650, 3652 AZ 3657, 3659	0.29 (X <sub>T</sub> = 0.6)

## Engineering Data — Pneumatic valves

Operating pressure	AZ 3540VS, 3542, 3571 AZ 3540 AZ 3580 AZ 3550 AZ 3000, 3002, 3080	Vacuum to 125 psig (9 bar) Vacuum to 145 psig (10 bar) Vacuum to 250 psig (17 bar) Vacuum to 300 psig (21 bar) Vacuum to 3,000 psig (207 bar)
Flow coefficient (C <sub>v</sub> )	AZ 3000, 3080 AZ 3002 AZ 3540, 3542, 3550, 3571, AZ 3580	0.23 (X <sub>T</sub> = 0.5) 0.28 (X <sub>T</sub> = 0.5) 0.29 (X <sub>T</sub> = 0.6)
Status	AZ 3000, 3002, 3540, 3542 AZ 3550, 3571 AZ 3080, 3580	Normally closed (NC) Normally closed (NC) Normally open (NO)
Actuation pressure	AZ 3000, 3002, 3540, 3550 AZ 3080, 3571, 3580 AZ 3542	70 to 110 psig (5 to 8 bar) 70 to 110 psig (5 to 8 bar) 60 to 110 psig (4 to 8 bar)
Actuation port	AZ 3000, 3002, 3080, 3540, AZ 3580 AZ 3542 AZ 3550, 3571	1/8 NPT, top port  M5 top port M5 side port

## Engineering Data — Other parameters all valves

Inlet and outlet connectors	1/4 and 3/8 inch face seal or tube weld
Internal volume	0.06 in <sup>3</sup> (1.07 cm <sup>3</sup> )
Operating temperature	-40° to +160° F (-40° to 71° C)*
Surface finish	10 μin Ra
Proof pressure	150% of operating pressures
Burst pressure	300% of operating pressures
Inboard leakage	2 x 10 <sup>-10</sup> sccs
Outboard leakage	2 x 10 <sup>-9</sup> sccs He
Leakage across seat	1 x 10 <sup>-9</sup> sccs He

## Engineering Data — Wetted materials all valves

Body	SS 316L**
Finish	Electropolished and passivated
Diaphragm	Ni-Co alloy / UNS R30003
Seat	PCTFE (Polyimide optional)

## AZ 3571 — Metered flow range tolerance at 80 psig N<sub>2</sub> inlet, 0 psig outlet

10 to 20 slpm	+/- 6 slpm
21 to 50 slpm	+/- 10 slpm
51 to 100 slpm	+/- 15 slpm
101 to 200 slpm	+/- 20 slpm
201 to 350 slpm (AZ 3571 only)	+/- 25 slpm

\*VS option 14° to 194°F (-10° to + 90°C).

All specifications subject to change without notice.

\*\*Sulfur content varies from forged to bar stock body. Refer to product note PN414 for use of single melt SS.

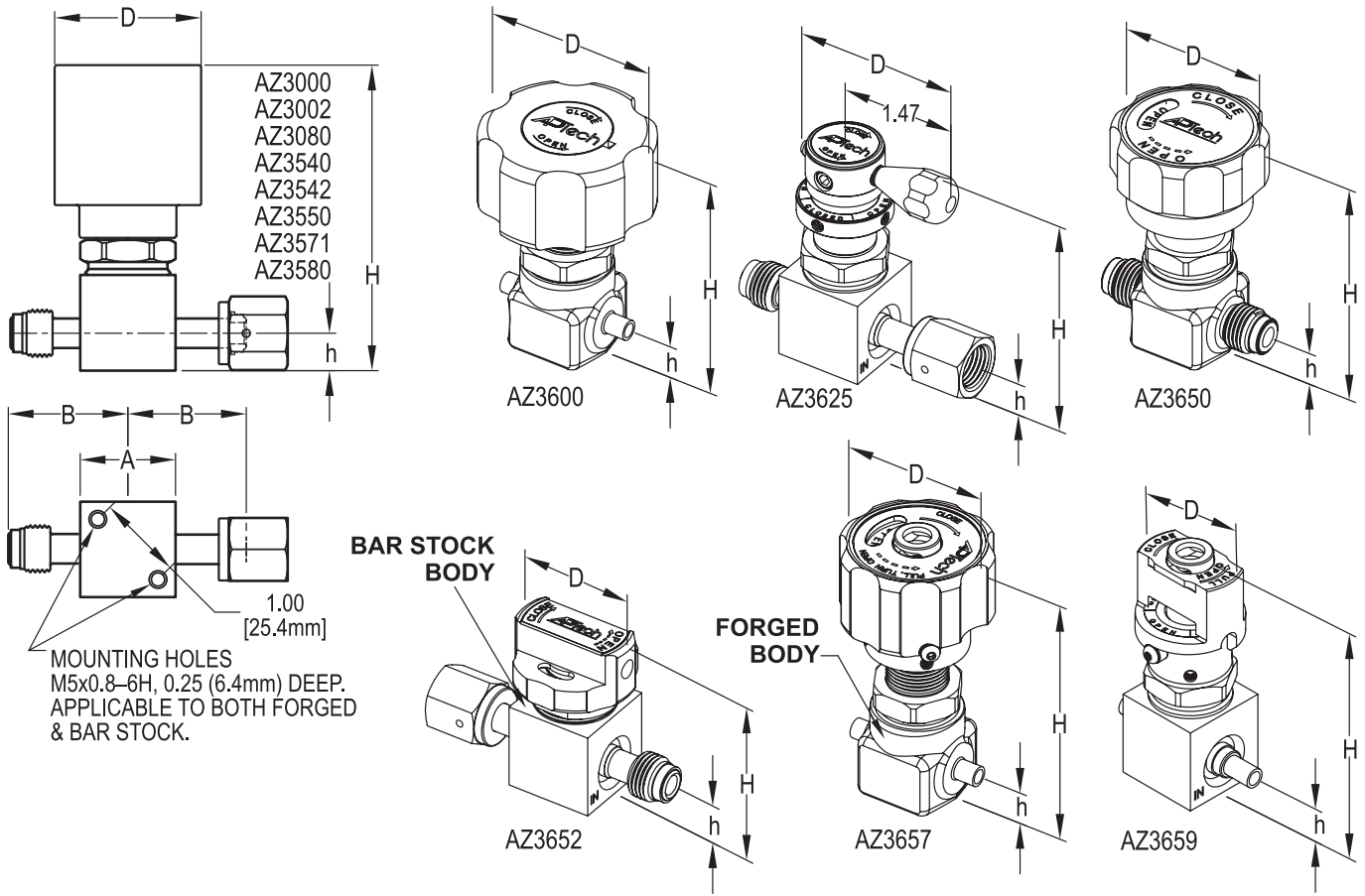

VALVE	D		H	
	inch	mm	inch	mm
AZ3000	ø1.98	50.3	~4.10	104
AZ3002	ø1.98	50.3	~4.10	104
AZ3080	ø1.98	50.3	~4.89	124
AZ3540	ø1.46	37.1	~3.49	89
AZ3542	ø1.57	40.0	~2.24	57
AZ3550	ø1.37	34.8	~3.28	83
AZ3571	ø1.72	43.7	~3.63	92
AZ3580	ø1.46	37.1	~3.17	81
AZ3600	ø2.12	53.8	~3.00	76
AZ3625	2.04	51.8	~2.94	75
AZ3650	ø1.87	47.5	~3.02	77
AZ3652	ø1.50	38.0	~2.17	55
AZ3657	ø1.87	47.5	~3.60	91
AZ3659	ø1.30	33.0	~3.13	80

- Forged body only available in 2P porting with same type fittings inlet and outlet.
- Bar stock body, PW porting, has welded fittings in any combination of available type and size.
- P porting denotes forged body or bar stock body with integrally machined fittings. PW porting denotes welded fittings.
- Height of the valve (H) is an approximate value.

All dimensions in inches (mm).

Metric dimensions are for reference only.

All specifications subject to change without notice.

All manual valves are shown in open position.

Sulfur content varies from forged to bar stock body.

BODY TYPE	PORTNG	CONNECTION	A		B		h	
			inch	mm	inch	mm	inch	mm
FORGED	P	MV4xMV4 (Fixed)	N/A	N/A	1.140	29.0	0.44	11.2
	P	TW4xTW4	N/A	N/A	0.875	22.2	0.44	11.2
BAR STOCK	PW	TW4	1.12 SQ	28.4	1.060	26.9	0.44	11.2
	PW	FV4, MV4 (Fixed)	1.12 SQ	28.4	1.390	35.3	0.44	11.2
	PW	FV6, MV6	1.12 SQ	28.4	1.930	49.0	0.44	11.2
	PW	TW6	1.12 SQ	28.4	1.325	33.7	0.44	11.2

# ULTRACLEAN TECHNOLOGY BACKED BY SERVICE AND SUPPORT

## Porting Options Available

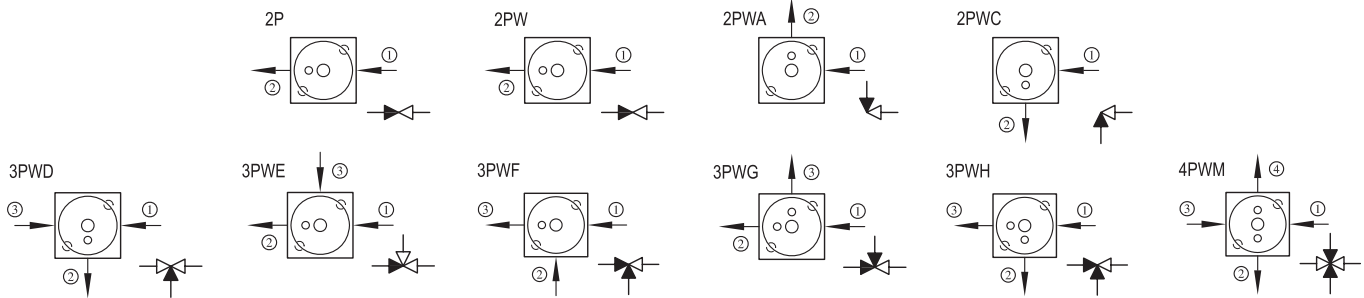

- Valves are illustrated top view looking down through the valve. Mounting holes on the valve bottom are shown for reference.
- INLET (Upstream) is defined as a port connected to the region below the valve seat. It is illustrated with an arrow pointing towards the valve body or an “empty” triangle on the schematic. OUTLET (Downstream) is defined as a port connected to the region above the seat and below the diaphragm. It is illustrated with an arrow pointing away from the valve body or a “filled” triangle on the schematic.
- The traditional flow direction is INLET to OUTLET, but AP Tech valves may be employed in either flow direction.
- End connections are specified in numerical order per the diagram’s numbered arrows.
- Multi-port is available only with bar stock (PW) body.

**CAUTION:** Product selection is the sole responsibility of the user, regardless of any recommendations or suggestions made by the factory. The user shall make selections based upon their own analysis and testing with regard to function, material compatibility and product ratings. Proper installation, operation and maintenance are also required to assure safe, trouble free performance.

PORTING CONFIGURATIONS

ORDERING INFORMATION

Sample Order Number

AZ 3652S 2P MV4 MV4

AZ 3652 | Series

AZ 3000, 3002, 3080  
AZ 3540, 3542, 3550  
AZ 3571, 3580  
AZ 3600, 3625  
AZ 3650, 3652, 3657, 3659

S | Material

S = Stainless steel (SS)

2P | Ports

2P = 2 ports  
2PW = 2 ports welded  
3PW = 3 ports welded  
4PW = 4 ports welded

Porting Designation Option

X = Letter code for available porting option  
Refer to porting options above.

MV4 MV4 | Connections Inlet / Outlet or

① ② ③ ④

Options

\*\*Refer to manual for installation information.

\*\*\*AZ 3542 has limited clearance for orbital weld head.

†NOTE: Replace XXX with flow rate using 3 digits, example 50 slpm = M050.

Porting P PW

FV4 = 1/4 inch face seal female  
MV4 = 1/4 inch face seal male\*  
TW4 = 1/4 inch tube stub weld  
FV6 = 3/8 inch face seal female  
MV6 = 3/8 inch face seal male  
TW6 = 3/8 inch tube stub weld

Refer to chart on page 3 for available connections.  
\*MV4 is fixed, no hex nut.

- Only available with the same type fitting inlet and outlet.
- Available with any combination of welded fitting.

1.75 = 1.75" face to face TW4 PW porting\*\*\*  
(1.75 is standard for 2P)

VS = Polyimide Seat

P = Panel mount, manual valves\*\*  
(except 3652, 3659 & 4659)

IPC = Indicating switch, NC\*\* (AZ 3550 & 3580 only)

IPO = Indicating switch, NO\*\* (AZ 3550 & 3580 only)

IS = Indicating switch\*\* (AZ 3000, 3002 & 3080 only)

ISH = Indicating switch\*\* (AZ 3650 only)

MXXX† = 3571 metered adjustment

AP Tech has product options and variations which are not documented in data sheets. If you have a model number that is not defined by the ordering information, please consult the factory or your local representative.