



# SERIES AZ 1500

## TIED DIAPHRAGM REGULATOR

Low Flow — High Pressure

- SS 316L construction
- 10  $\mu$ m. surface finish (25  $\mu$ m. optional)
- Vacuum to 3500 psig (241 bar) inlet  
HR option to 4,500 psig (310 bar)
- 1 to 150 psig (0.07 to 10 bar) outlet
- Cleaned, assembled and packaged for high purity semiconductor applications
- Regulator of choice for low flow source cabinet applications
- Knob LOTO (refer to AP KL data sheet)
- Installation and operating instructions available at [www.aptech-online.com](http://www.aptech-online.com) in the Tech Briefs section

### Operating Parameters

Source pressure	vacuum to 3,500 psig (241 bar) HR option vacuum to 4,500 psig (310 bar)
Delivery pressure	AZ 1502 1 to 30 psig (0.07 to 2 bar) AZ 1506 2 to 60 psig (0.14 to 4 bar) AZ 1510 2 to 100 psig (0.14 to 7 bar) AZ 1515 5 to 150 psig (.34 to 10 bar)
Proof pressure	150% of operating pressures
Burst pressure	300% of operating pressures

### Other Parameters

Inlet/outlet connectors	1/4 or 3/8 inch face seal or tube weld
Flow coefficient (Cv)	0.09 (0.15 HF option)
Internal volume	0.51 in <sup>3</sup> (8.4 cm <sup>3</sup> )
Operating temperature	-40° to +160°F (-40° to +71°C)*
Surface finish	10 $\mu$ m. (0.25 $\mu$ m) Ra avg. standard 25 $\mu$ m. (0.62 $\mu$ m) Ra avg. optional
Inboard leakage	2 x 10 <sup>-10</sup> sccs
Outboard leakage	2 x 10 <sup>-9</sup> sccs He
Leakage across seat	4 x 10 <sup>-8</sup> sccs He
Installation	surface or panel (optional)
Supply pressure effect	0.25 psig per 100 psig source pressure change HF 0.75 psig per 100 psig source pressure change

\*VS option 14° to 194°F (-10° to + 90°C).

### Materials

	Series AZ 1500 S	Series AZ 1500 SHP
Wetted Parts		
Body, nozzle	SS 316L**	SS 316L**
Poppet, diaphragm	SS 316L	Ni-Cr-Mo alloy / UNS N06022
Finish	electropolished and passivated	electropolished and passivated
Seat	PCTFE (Polyimide optional)	PCTFE

All specifications subject to change without notice.

\*\*Please refer to product note PN 414 regarding single melt 316L SS material.

# ULTRACLEAN BY DESIGN AND MANUFACTURING

## DIMENSIONAL INFORMATION

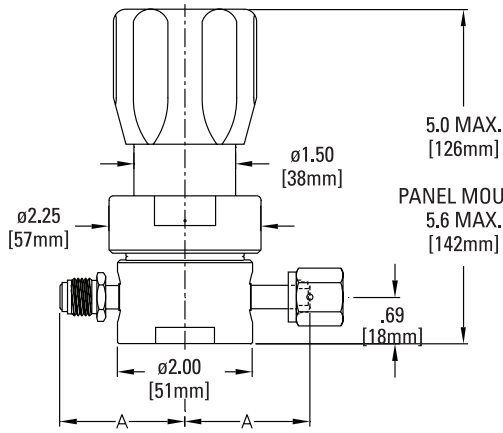

All dimensions in inches. Metric dimensions (mm) are for reference only.

Face Seal	A	
	in	mm
1/4"	1.85 ±.01	47
3/8"	2.35 ±.02	60

## PORTING CONFIGURATIONS

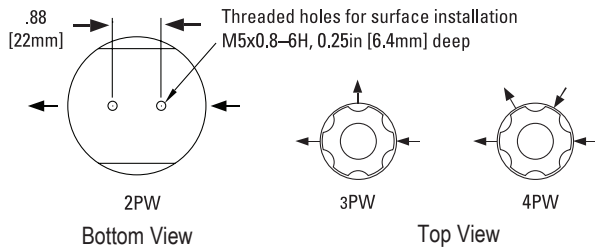

**CAUTION:** Product selection is the sole responsibility of the user, regardless of any recommendations or suggestions made by the factory. The user shall make selections based upon their own analysis and testing with regard to function, material compatibility and product ratings. Proper installation, operation and maintenance are also required to assure safe, trouble free performance.

## ORDERING INFORMATION

Sample Order Number	AZ 1510SQ 2PW FV4 FV4	
<b>AZ 1510</b>   Series	AZ 1502 = 1-30 psig (.07 to 2 bar) AZ 1506 = 2-60 psig (.14 to 4 bar) AZ 1510 = 2-100 psig (.14 to 7 bar) AZ 1515 = 5-150 psig (.34 to 10 bar)	
<b>S</b>   Material	S = Stainless steel SHP = SS/Ni-Cr-Mo alloy poppet and diaphragm	
<b>Q</b>   Surface Finish Option	Q = 25 µin. Ra avg.	
<b>2PW</b>   Ports	2PW = 2 ports butt weld 3PW = 3 ports butt weld 4PW = 4 ports butt weld	
<b>FV4 FV4</b>   Connections Inlet / Outlet	FV4 = 1/4 inch face seal female MV4 = 1/4 inch face seal male FV6 = 3/8 inch face seal female MV6 = 3/8 inch face seal male  Tube weld stub available	
<b>Gauges*</b> Source / Delivery	0 = No gauge V3 = 30-0-30 psig/bar L = 30-0-60 psig/bar 1 = 30-0-100 psig/bar H = 30-0-160 psig/bar 10 = 0-1000 psig/bar 40 = 0-4000 psig/bar 50 = 0-5000 psig/bar  * Standard gauge port is 1/4 inch face seal male (1/4 inch face seal female are available).	
<b>Options</b>	VS = Polyimide seat P = Panel installation** HR = High inlet rating*** HF = High flow KL = Knob LOTO (refer to AP KL data sheet)	

AP Tech has product options and variations which are not documented in data sheets. If you have a model number that is not defined by the ordering information, please consult the factory or your local representative.

\*\*Panel hole 1.56" diameter.  
 \*\*\*HR option not available with 3/8 inch fittings, tube stubs, nor with HF option.

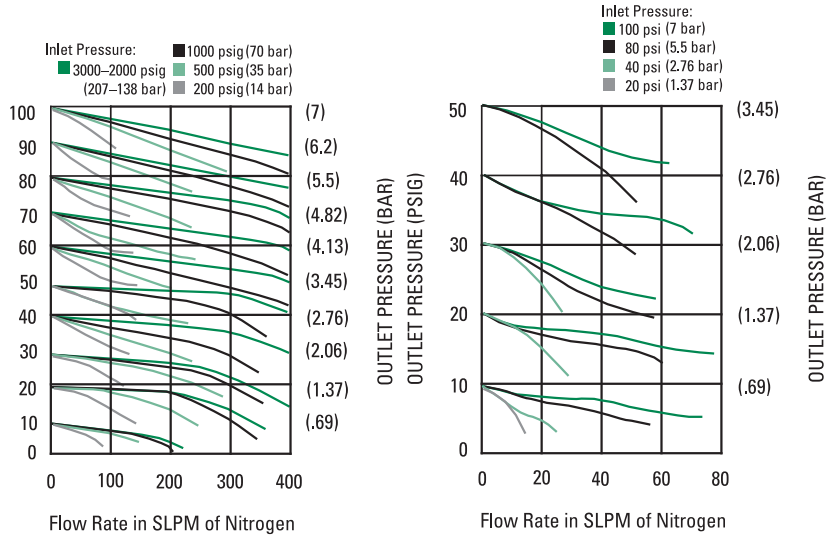

**MODEL AZ 1500 HF** Flow Curve at 150 psig Inlet Pressure

